

# RBC Roller® Cam Followers

## The Superior Alternative

The Patented Cylindrical RBC Roller® Cam Follower  
A Clear Winner with Competitive Prices



RBC Division  
ISO 9001:2000

[www.rbcbearings.com](http://www.rbcbearings.com)  
800.390.3300

# Patented Cylindrical Roller Cam Followers

RBC invented the RBC Roller® to solve a host of problems associated with old-style needle roller cam followers.

## RBC Roller® Cam Follower

### *The Superior Alternative*

- RBC Roller® cam followers are available in sizes from 1" in roller diameter — an industry exclusive.
- Invented by RBC to solve some of the toughest machine and product control guidance challenges.
- Double row of cylindrical rollers delivers tremendous operating advantages in an economical package.
- Repair and replace cycle is greatly reduced — RBC Roller® cam followers operate up to 5 times longer.
- “Lubricated for life” — No more need for periodic relubrication or expensive automatic lubrication systems.
- Operate at much higher rotary speeds — RBC Roller® cam followers operate at speeds up to 2 times higher.
- Increase load carrying capacity without increasing cam follower size — Up to double the dynamic load rating.
- Unique contacting lip seals provide positive protection against contamination while keeping grease inside.
- Specialty configurations (i.e., double outer ring) and corrosion resistance (thin, dense chrome plating) available.

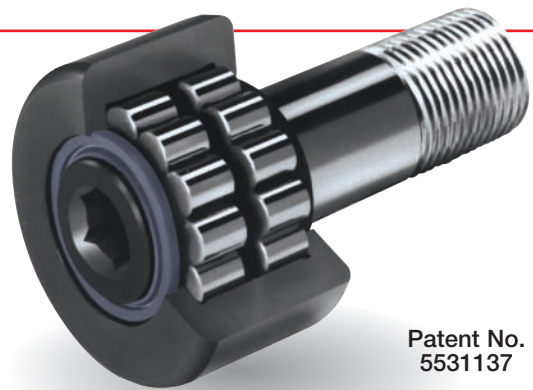

Patent No.  
5531137

## Needle Roller Cam Follower

### *Old Generation Technology*

- Performance capability limited by old design.
- Must be relubricated to prevent early failure.
- Roller skewing raises operating temperature.
- Needle rollers limit load carrying capacity.
- Gap seals allow intrusion of contamination.
- Inaccurate roller guidance limits operating speed.
- Minimal resistance to thrust loads.

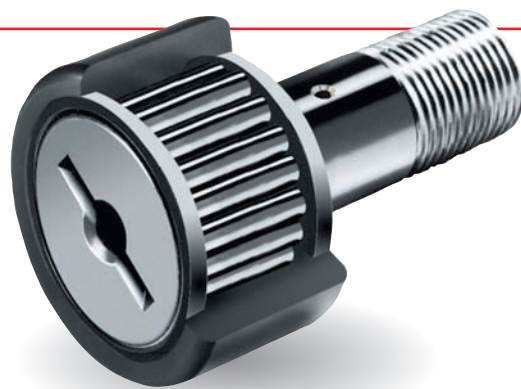

## Precisely Guided Cylindrical Rollers

The use of precisely guided rollers dramatically improves all aspects of cylindrical roller cam follower performance. The dynamic load capacity, maximum running speed, and fatigue life are greatly enhanced. See the charts below for specific data regarding these improvements. Lower performance needle roller cam followers rely on rolling elements that have reduced load capacity. They are also subject to more rolling resistance, and generate higher operating temperatures. These unfavorable operating characteristics are the result of comparatively small roller diameter (reduced load capacity) and poor roller guidance, resulting in skewing (excessive frictional heat and reduced fatigue life).

## The Best Seals in the Business

Advanced RBC Roller® sealing technology provides long-term protection for the rolling element system.

Without effective sealing, even the performance of RBC's precision roller guidance and cylindrical roller technology would be diminished. The contact lip seals provide sealing effectiveness for the cam follower's full operating life. By keeping grease inside the cam follower and contaminants away from the rolling elements, RBC Roller® contact lip seals provide a "lubed for life" product.



▲ RBC Roller® — latest technology

▲ Needle roller — older technology

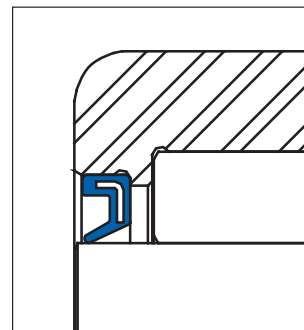

Latest RBC Roller® seal design

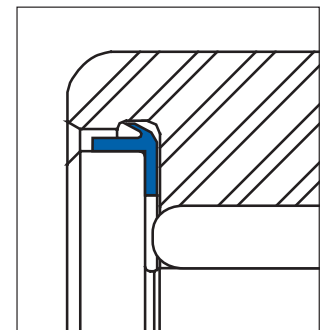

Old style needle roller cam follower gap seal

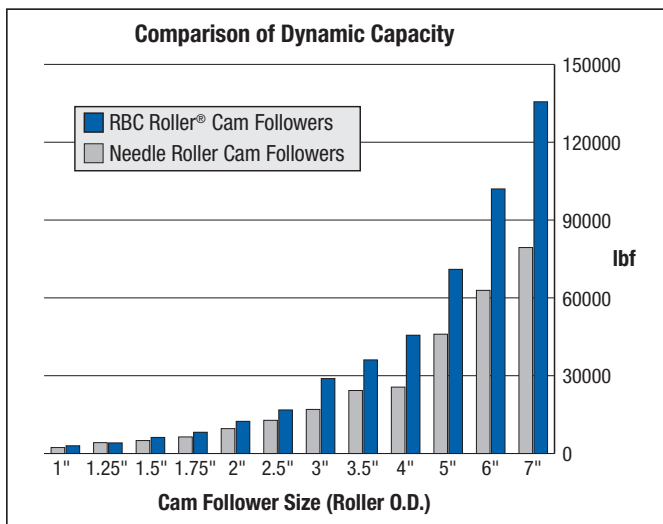

This chart shows the superior load capacity of the RBC Roller® cam follower.

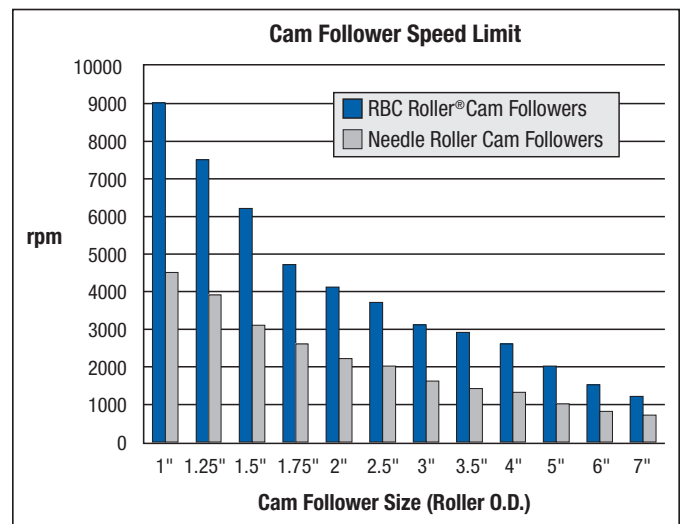

RBC Roller® cam followers operate at speeds up to 2 times higher than needle roller cam followers.

# The RBC Roller® Cam Follower Advantage

## RBC Roller® Cam Follower

### *The Latest Design and Technology Innovations*

Patented RBC Roller® double row cylindrical roller cam followers represent the most effective cam follower technology available. They are superior to needle roller cam followers in every way — “lubed for life,” higher load capacity, higher speed rating, and longer service life.

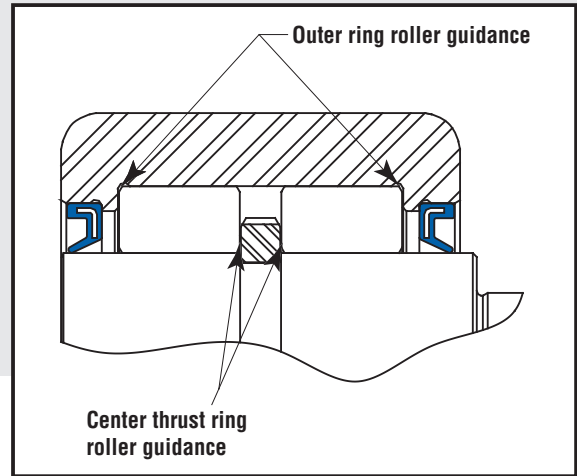

## RBC Roller® Cam Follower

### Contacting Lip Seals

These seals make contact only with the stud ground diameter, therefore maximizing seal life. They are not subject to thrust load against unground surfaces. Their sole function is to provide a secure seal for the retention of lubricant and exclusion of contaminants.

### Dual Row Cylindrical Rollers

Large diameter rollers carry high loads. Higher dynamic capacity results in greater fatigue life – greatly prolonging cam follower service life.

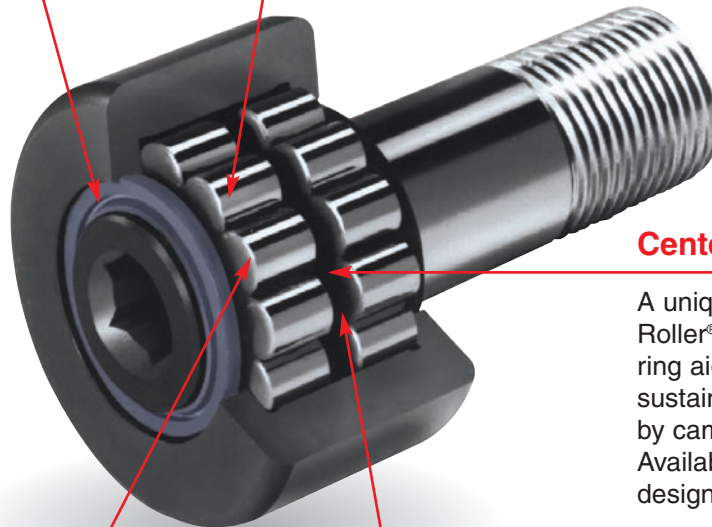

### Center Thrust Ring

A unique element of the RBC Roller® design, the center thrust ring aids in roller guidance and sustains thrust loads generated by cam follower misalignment. Available only in RBC's patented design.

### Precise Roller Guidance

RBC Roller® cam followers typically run up to 50° F cooler due to accurate roller travel. Cylindrical rollers are guided by both the center thrust ring and internal shoulders of the outer ring.

### Large Grease Reservoir

Area between the roller paths is fully charged with up to 4 times more grease than like-sized needle roller cam followers. This additional grease helps to ensure “lubed for life” performance. Eliminates the need for periodic relubrication.

## Needle Roller Cam Follower

### *Previous Generation Design and Performance*

Long, small diameter needle rollers mean lower load capacity, limited speed, and higher operating temperatures. The combination of minimal grease charge volume and more rapid lubricant degradation mean that relubrication is required for even moderate service life.

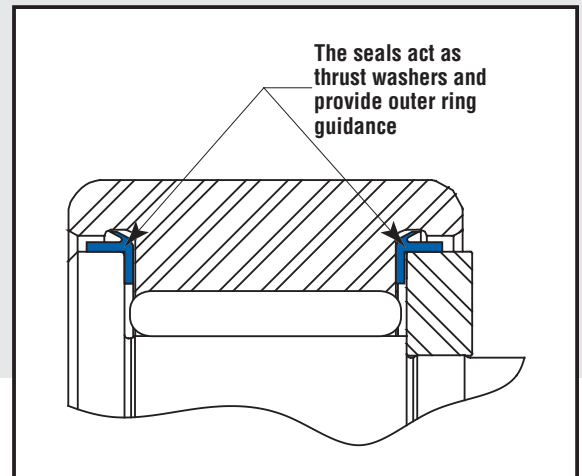

## Needle Roller Cam Follower

### Gap Seals

These seals are designed to fill the gap between outer ring shoulder and the end ring (see above illustration). This results in substantial frictional and thrust loads on seal surfaces that can lead to rapid wear.

### Single Row Needle Rollers

Larger number of small diameter rollers results in lower load rating and reduced fatigue life.

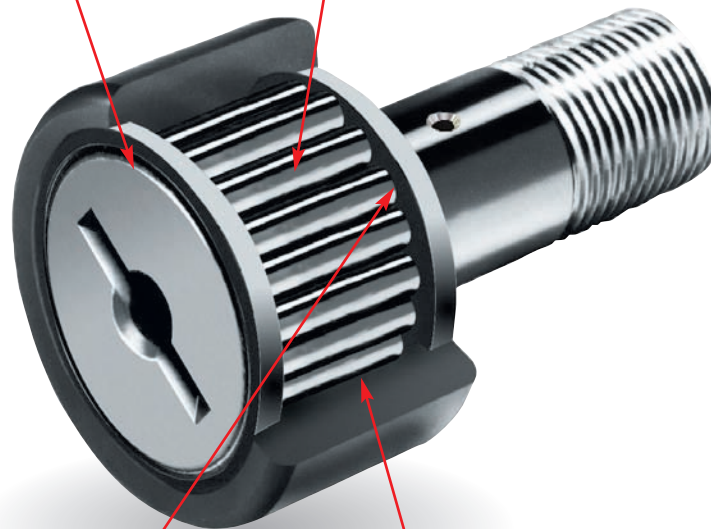

### Limited Roller Guidance

End-guided needle rollers tend to skew during normal operation. This can result in excessive heat generation, which can lead to deterioration of the already limited grease supply.

### Minimal Grease Retention Volume

The only available area for grease charge is between the rollers. Cam follower life is directly related to effective lubrication. Relubrication of needle roller cam followers is required to maximize life.



# RBC Stud Type and Yoke Roller Type Cam Follower Dimensions

RBC Roller® — Stud Type

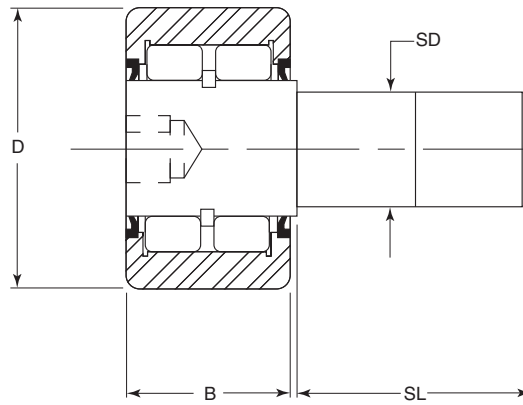

Part Number	Part Number	D +.000 -.001	B +.000 -.005	Stud Type Only		Yoke Type Only		
				SD +.0010 -.0000	SL Stud Length	d Inside Diameter		
						Nom.	Min.	Max.
RBC 1*	RBV 1	1.000	.625	.4375	1.000	5/16	.3121	.3127
RBC 1 1/8*	RBV 1 1/8	1.125	.625	.4375	1.000	5/16	.3121	.3127
RBC 1 1/4	RBV 1 1/4	1.250	.750	.5000	1.250	3/8	.3746	.3752
RBC 1 3/8	RBV 1 3/8	1.375	.750	.5000	1.250	3/8	.3746	.3752
RBC 1 1/2	RBV 1 1/2	1.500	.875	.6250	1.500	7/16	.4371	.4377
RBC 1 5/8	RBV 1 5/8	1.625	.875	.6250	1.500	7/16	.4371	.4377
RBC 1 3/4	RBV 1 3/4	1.750	1.000	.7500	1.750	1/2	.4996	.5002
RBC 1 7/8	RBV 1 7/8	1.875	1.000	.7500	1.750	1/2	.4996	.5002
RBC 2	RBV 2	2.000	1.250	.8750	2.000	5/8	.6246	.6252
RBC 2 1/4	RBV 2 1/4	2.250	1.250	.8750	2.000	5/8	.6246	.6252
RBC 2 1/2	RBV 2 1/2	2.500	1.500	1.0000	2.250	3/4	.7496	.7502
RBC 2 3/4	RBV 2 3/4	2.750	1.500	1.0000	2.250	3/4	.7496	.7502
RBC 3	RBV 3	3.000	1.750	1.2500	2.500	1	.9995	1.0001
RBC 3 1/4	RBV 3 1/4	3.250	1.750	1.2500	2.500	1	.9995	1.0001
RBC 3 1/2	RBV 3 1/2	3.500	2.000	1.3750	2.750	1 1/8	1.1245	1.1251
RBC 4	RBV 4	4.000	2.250	1.5000	3.500	1 1/4	1.2495	1.2501
RBC 5	RBV 5	5.000	2.750	2.0000	5.062	1 3/4	1.7495	1.7501
RBC 6	RBV 6	6.000	3.250	2.5000	6.000	2 1/4	2.2495	2.2501
RBC 7	RBV 7	7.000	3.750	3.0000	7.688	2 3/4	2.7495	2.7501
RBC 8	RBV 8	8.000	4.250	3.2500	8.500	3 1/4	3.2550	3.2560
RBC 9	RBV 9	9.000	4.750	3.7500	9.500	3 3/4	3.7550	3.7560
RBC 10	RBV 10	10.000	5.250	4.2500	10.000	4 1/4	4.2550	4.2560

\*1" and 1 1/8" are industry-exclusive sizes

# and Performance Data

RBC Roller® — Yoke Type

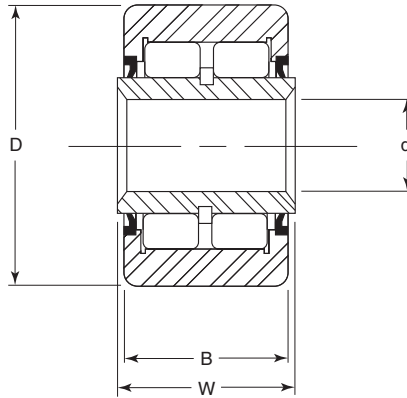

W Overall Width +.0050 -.0100	Speed Limit (rpm)	C Bearing Dynamic Capacity (lbf)
.6925	9,400	3,000
.6925	9,400	3,000
.8125	7,500	4,100
.8125	7,500	4,100
.9375	6,200	6,200
.9375	6,200	6,200
1.0625	4,700	8,200
1.0625	4,700	8,200
1.3125	4,100	12,400
1.3125	4,100	12,400
1.5625	3,700	16,800
1.5625	3,700	16,800
1.8125	3,100	28,900
1.8125	3,100	28,900
2.0625	2,900	36,100
2.3125	2,600	45,600
2.8750	2,000	71,000
3.3750	1,500	102,000
3.8750	1,200	135,600
4.5000	1,100	175,400
5.0000	1,000	221,000
5.5000	900	272,000

Needle Roller Cam Followers			
Nominal Size	Part Number	Speed Limit (rpm)	C Bearing Dynamic Capacity (lbf)
1	S 32	4,500	2,300
1 1/8	S 36	4,500	2,300
1 1/4	S 40	3,900	4,200
1 3/8	S 44	3,900	4,200
1 1/2	S 48	3,100	5,000
1 5/8	S 52	3,100	5,000
1 3/4	S 56	2,600	6,400
1 7/8	S 60	2,600	6,400
2	S 64	2,200	9,600
2 1/4	S 72	2,200	9,600
2 1/2	S 80	2,000	12,800
2 3/4	S 88	2,000	12,800
3	S 96	1,600	17,000
3 1/4	S 104	1,600	17,000
3 1/2	S 112	1,400	24,300
4	S 128	1,300	30,000
5	S 160	1,000	47,200
6	S 192	800	62,900
7	S 224	700	79,400

- All sizes are available in crowned and oil hole versions
- Heavy stud style available in some sizes
- Contact Customer Service at 800.390.3300 with questions



# Innovation. Commitment. Quality.

RBC has been producing bearings in the USA since 1919. In addition to unique custom bearings, RBC offers a full line of standard industrial and aerospace bearings, including:



## Spherical Plain Bearings

Radial, angular contact, extended inner ring, high misalignment. **QuadLube**<sup>®</sup>, **ImpactTuff**<sup>®</sup>, **SpreadLock**<sup>®</sup> Seal, **CrossLube**<sup>®</sup>, **DuraLube**<sup>™</sup>, and self-lubricating bearings. Available in inch and metric sizes.



## Needle Roller Bearings

**Pitchlign**<sup>®</sup> caged heavy duty needle roller bearings, inner rings, **TJ TandemRoller**<sup>®</sup> bearings for long life.



## Thin Section Ball Bearings

Standard cross sections to one inch. Sizes to 40 inches. Stainless steel and other materials are available. Seals are available on all sizes and standard cross sections. Super duplex configurations.



## Self-Lubricating Bearings

Radial, thrust, rod ends, spherical bearings, high temperature, high loads. Available in inch and metric sizes. **Fiberglide**<sup>®</sup> self-lubricating bearings.



## Tapered Roller Bearings

**Tyson**<sup>®</sup> case-hardened and through-hardened tapered roller bearings. Available in many sizes. Used in Class 8 heavy truck and trailer wheel bearings, gearboxes, and final drive transmissions.



## Airframe Control Bearings

Ball bearing types, self-lubricating types, needle roller track rollers.



## Tapered Roller Thrust Bearings

Case-hardened. Sealed and unsealed for truck, tractor, and construction equipment steer axles, and Class 8 trailer landing gear.



## Dowel Pins, Loose Needle Rollers, Shafts

**Precision Products** dowel pins, loose needle rollers, and shafts.



## Ball Screws

Precision ground, rolled, ball splines. Long life, low wear, high accuracy. **QuickTurn**<sup>®</sup> Ball Screw Repair Service.



## Commercial Rod Ends

Commercial and industrial, precision, Mil-Spec series, self-lubricating, and aircraft. Sold under the **Heim**<sup>®</sup>, **Unibal**<sup>®</sup>, and **Spherco**<sup>®</sup> names. Available in inch and metric sizes.



## Integrated Assemblies

For robots and other process tool applications. Engineering design assistance. Production volume capacity.



## Ball Bearings

Precision ground, semiground, unground. High loads, long life, smooth operation. **Nice**<sup>™</sup> branded products are offered in caged and full complement configurations.



## Cam Followers

Standard stud, heavy stud, yoke type, caged roller followers. Patented **RBC Roller**<sup>®</sup> cylindrical roller cam followers, **HexLube**<sup>®</sup> universal cam followers, airframe track rollers.



## Specials

RBC manufactures many specialty bearings for the aerospace, oil and energy, semiconductor equipment, packaging, transportation, and other industries.